

Copyright (c) by electrotechnische industrie ETI b.v.. No part of this drawing may be reproduced or distributed in any form or by any means or stored in a database or retrieval system, without the prior written permission of ETI b.v..

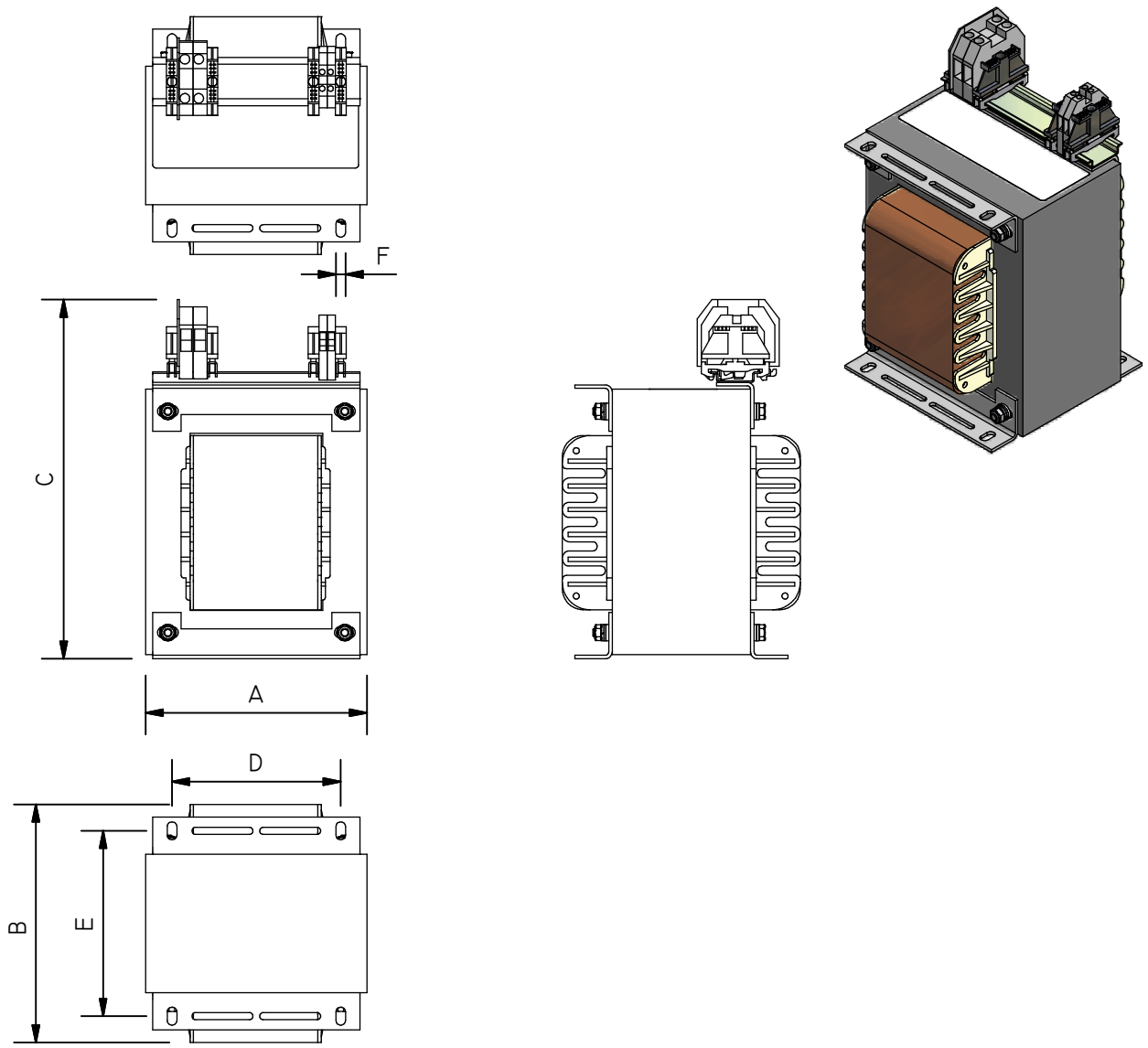

MODEL		A	B	C	D	E	F	MASS (KG)
CKI56	CK256	125	120	215	85	100	7	7,9
CKI57	CK257	125	136	215	85	116	7	9,8
CKI75	CK275	125	150	215	85	130	7	11,7
CKI58	CK258	125	162	215	85	142	7	13
CKI59	CK259	145	122	240	102	102	7	11,6
CKI60	CK260	145	132	240	102	112	7	13,1
CKI61	CK261	145	142	240	102	122	7	14,8
CKI62	CK262	145	152	240	102	132	7	16,8
CKI63	CK263	145	172	240	102	152	7	20,5
CKI67	CK267	160	146	260	112	126	7	16,6
CKI68	CK268	160	150	260	112	130	7	17,7
CKI69	CK269	160	162	260	112	142	7	20,1
CKI70	CK270	160	180	260	112	160	7	23,1
CKI71	CK271	160	190	260	112	170	7	25,3
CKI90		260	185	260	205	115	8,5	30
CKI91		260	205	260	205	135	8,5	36
CKI92		260	220	260	205	150	8,5	41
CKI93		260	230	260	205	160	8,5	44

ITEM	QTY	PART NO	DESCRIPTION	MATERIAL	REMARKS
PROJ AM		SCALE : 1 : 5		DRW : HTK	
UNITS : MM		DATE : 21-12-2006		PART NO :	
DESCRIPTION :		SHEET: OF:		DWG NO :	
DIMENSIONS CK...		REV :		CK....IDW	
Aalten-NL		FORMAT :		A4	