

Copyright (c) by electrotechnische industrie ETI b.v.. No part of this drawing may be reproduced or distributed in any form or by any means or stored in a database or retrieval system, without the prior written permission of ETI b.v..

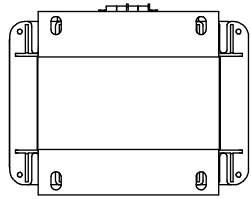
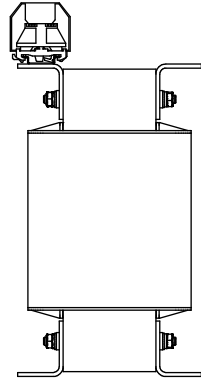
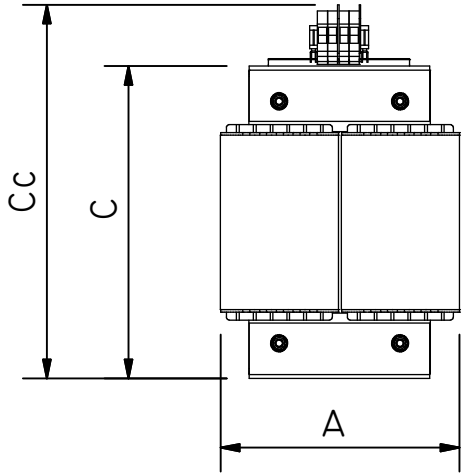
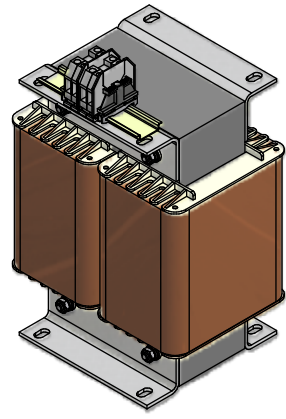
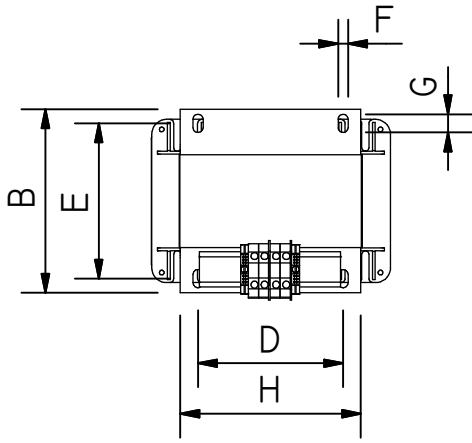



TABLE										
MODEL	A	B	C	Cc	D	E	F	G	H	MASS (KG)
CU456	173	106	225	295	112	76	10	18	132	14
CU458	173	132	225	295	112	106	10	18	132	21
CU454	195	147	269	325	124	119	10	18	150	29
CU463	236	153	310	375	144	125	10	18	180	37
CU464	236	168	310	375	144	140	10	18	180	44
CU465	236	183	310	375	144	155	10	18	180	50
CU438	276	173	370	434	176	143	13	20	210	59
CU439	276	203	370	434	176	173	13	20	210	78
CU472	314	193	420	491	196	157	13	20	240	88
CU473	314	220	420	491	196	184	13	20	240	110
CU474	314	250	420	491	196	214	13	20	240	135

ITEM	QTY	PART NO	DESCRIPTION	MATERIAL	REMARKS
PROJ AM			SCALE :	DRW : HTK	REMARKS :
			UNITS : MM		
			DATE : 7-9-2006	PART NO :	
			DESCRIPTION :	SHEET: OF:	DWG NO :
			DIMENSIONS CU...	REV :	CU....IDW
					FORMAT : A4