

Copyright (c) by electrotechnische industrie ETI b.v. . No part of this drawing may be reproduced or distributed in any form or by any means or stored in a database or retrieval system, without the prior written permission of ETI b.v.

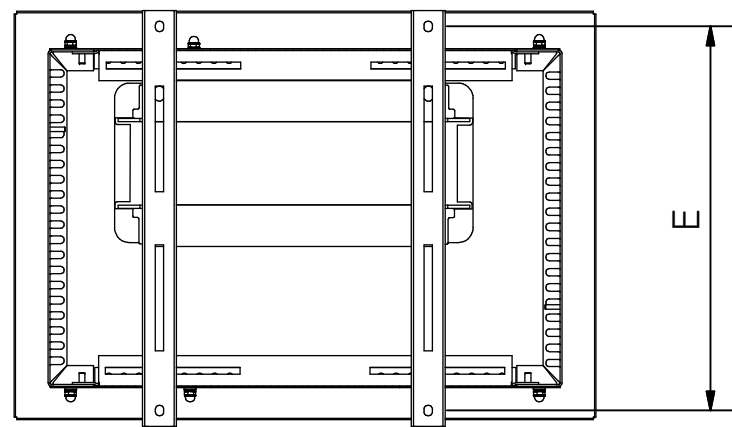
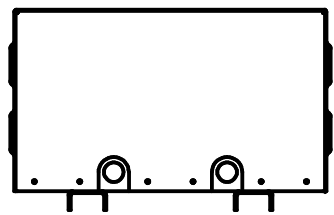
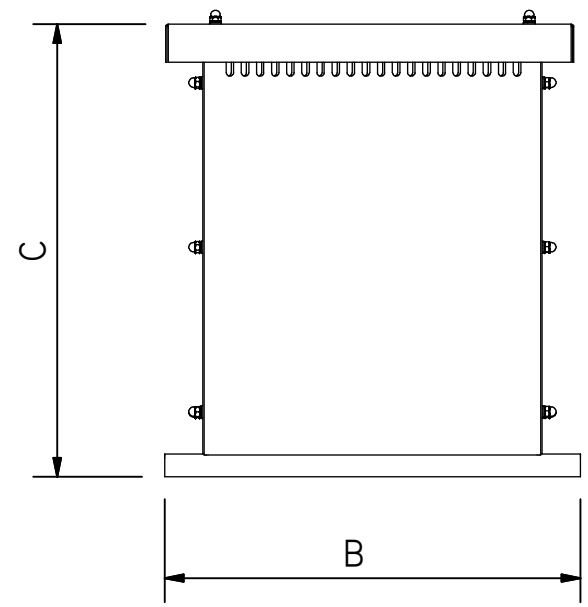
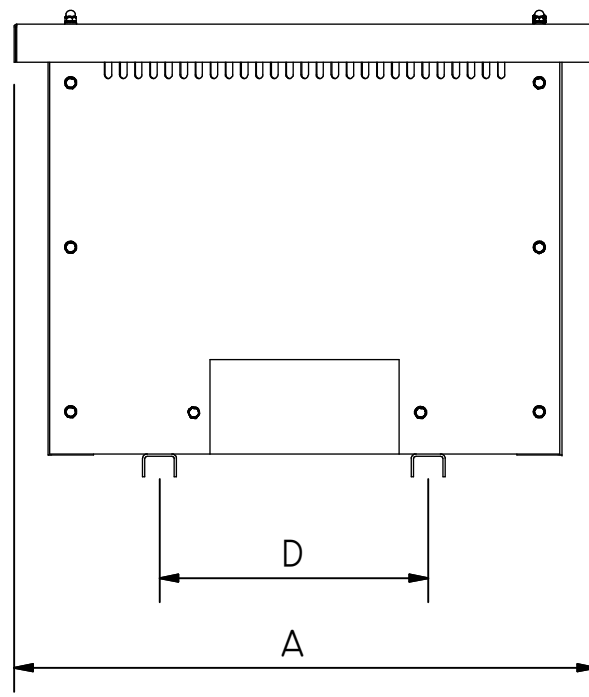
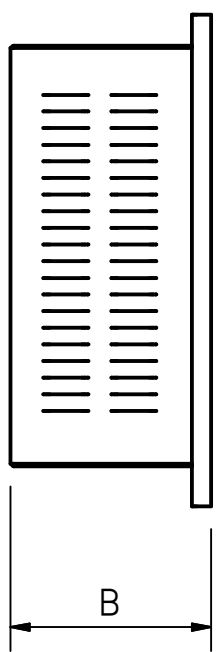
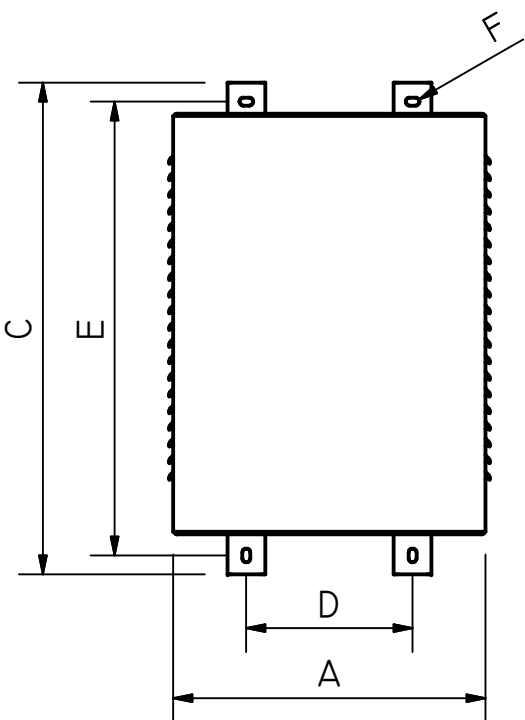
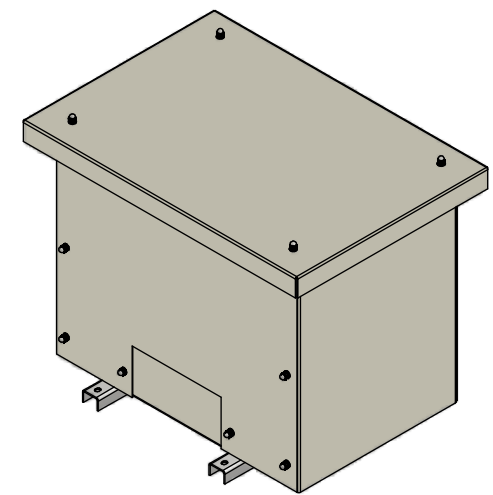
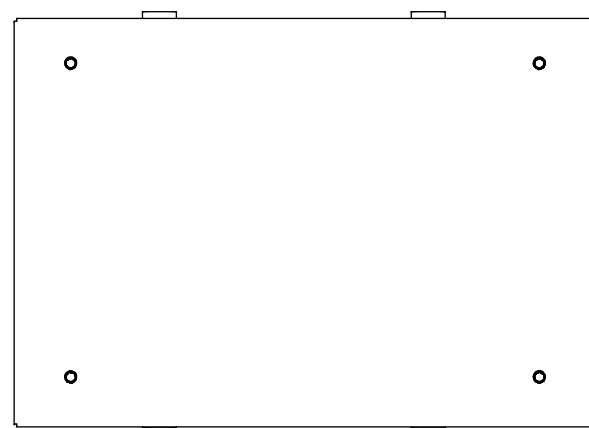
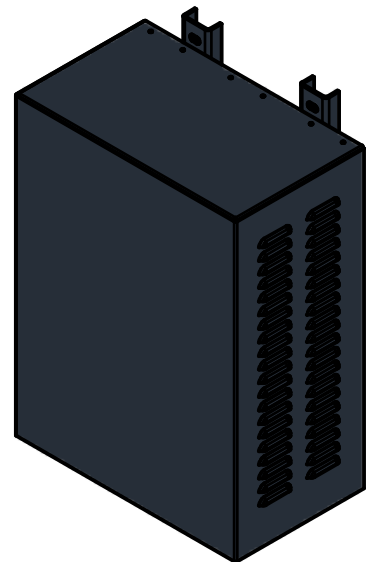
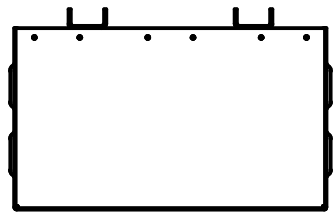

MODEL	A	B	C	D	E	F	MASS (KG)
FZ349	197	213	218	122	188	8	6.2
FZ350	197	213	218	122	188	8	11
FZ351	319	277	430	176	400	8	14,5
FZ352	319	277	430	176	400	8	15
FZ353	319	277	430	176	400	8	16.5
FZ354	319	277	430	176	400	8	20
FZ355	319	277	430	176	400	8	26.5
FZ356	413	265	650	220	600	18x10.5	38.5
FZ358	413	265	650	220	600	18x10.5	48.5
FZ360	413	265	650	220	600	18x10.5	60.5
FZ363	413	265	650	220	600	18x10.5	72.5
FZ364	413	265	650	220	600	18x10.5	82.5
FZ365	413	265	650	220	600	18x10.5	92.5

MODEL	A	B	C	D	E	MASS (KG)
FZ368	670	500	525	316	460	112
FZ370	670	500	525	316	460	140
FZ371	670	500	525	316	460	168
FZ372	770	550	605	356	510	160
FZ373	770	550	605	356	510	194
FZ374	770	550	605	356	510	231
FZ379	855	630	665	370	590	356

ITEM	QTY	PART NO	DESCRIPTION	MATERIAL	REMARKS
PROJ AM			SCALE :	DRW : HTK	REMARKS :
			UNITS : MM		
			DATE : 13-05-2014	PART NO :	
			DESCRIPTION :	SHEET: OF:	DWG NO :
			DIMENSIONS FZ...	REV : 2	FZ....IDW
					FORMAT : A3