

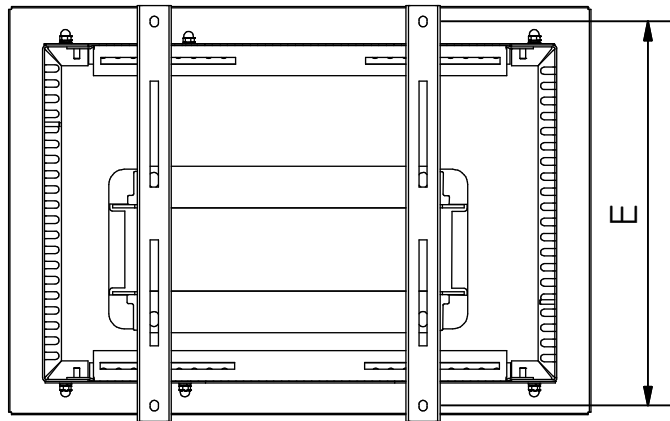

Copyright (c) by electrotechnische industrie ETI b.v.. No part of this drawing may be reproduced or distributed in any form or by any means or stored in a database or retrieval system, without the prior written permission of ETI b.v..

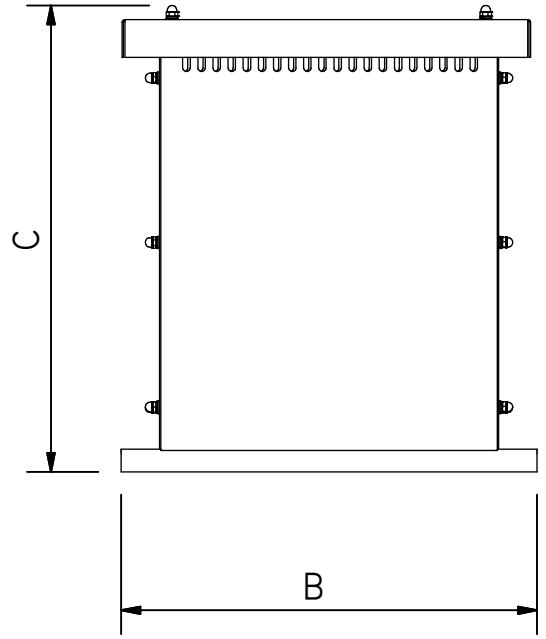
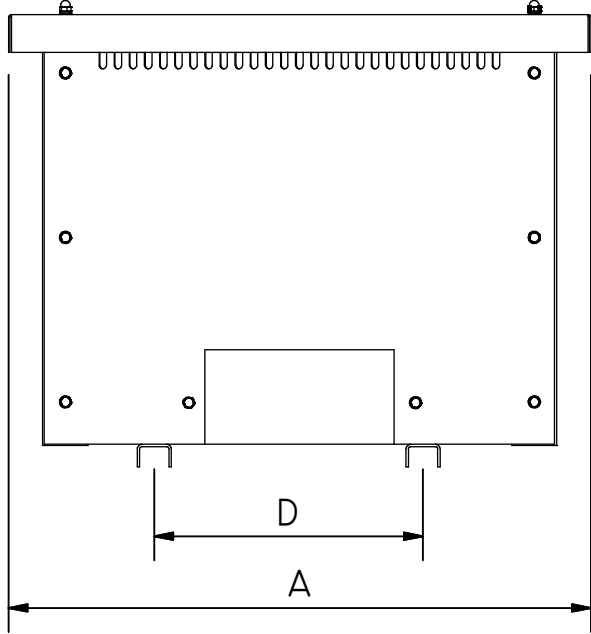
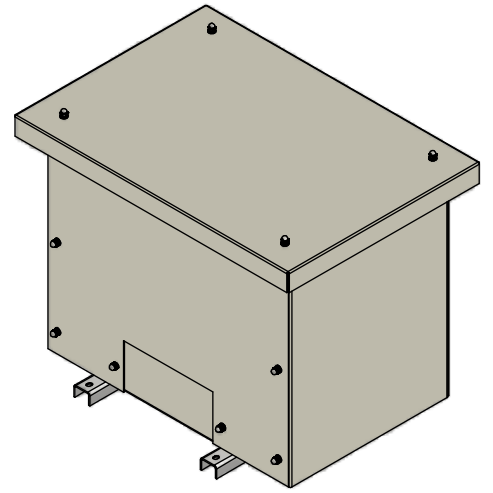
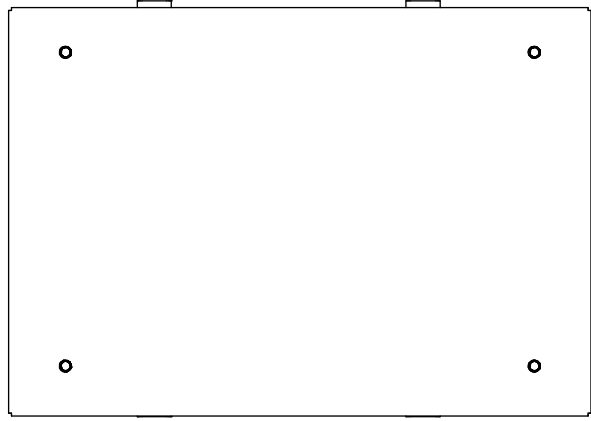

MODEL	A	B	C	D	E	MASS (KG)
FZ322	855	620	662	380	590	260
FZ323	730	460	650	400	420	285
FZ324	810	490	730	430	440	335
FZ325	860	500	770	470	450	420
FZ326	860	500	810	470	450	475
FZ327	940	550	900	510	500	580
FZ328	1010	600	940	550	550	680
FZ329	1110	630	980	620	580	855
FZ330	1210	650	1050	680	600	1100
FZ331	1240	720	1085	700	670	1270

ITEM	QTY	PART NO	DESCRIPTION	MATERIAL	REMARKS
PROJ AM		SCALE :		DRW : HTK	
A		UNITS : MM		REMARKS :	
		DATE : 07-05-2013		PART NO :	
		DESCRIPTION :		SHEET: OF:	
		DIMENSIONS FZ...(2)		REV : 2	
				DWG NO : FZ...(2).IDW	
				FORMAT : A4	